

jednostranný odhrotovač

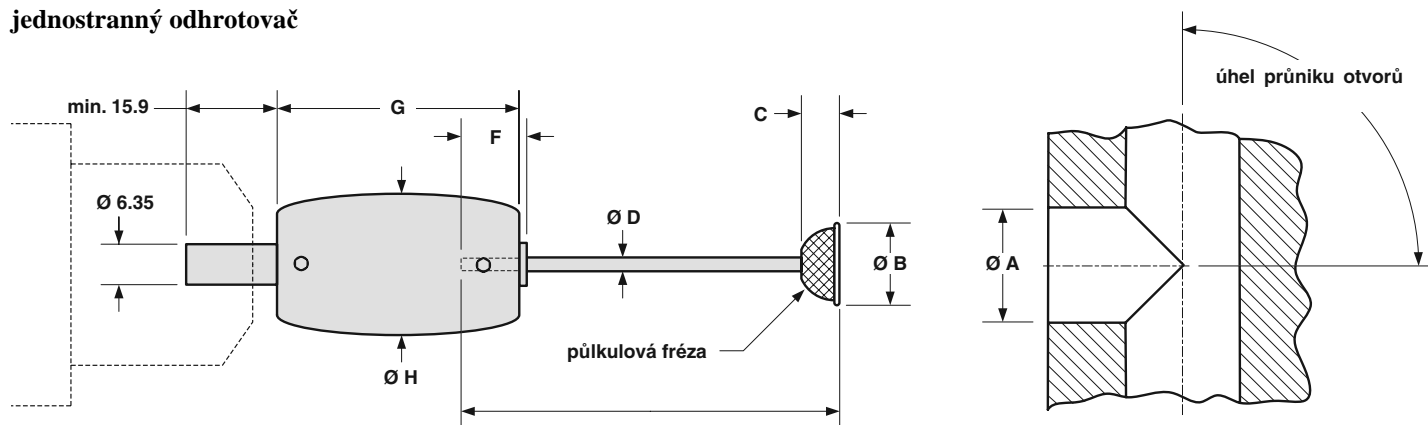

doporučení:
stopku je potřeba zkrátit na optimální délku

rozměr v mm/"	obj. číslo			min. průměr otvoru A v závislosti na úhlu průniku otvorů			Ø B nákržek	C výška frézy	Ø D stopka	E délka stopky	F		G	Ø H
	kompletní nástroj	pružný držák	fréza	90°	60°	45°					min.	max.		
2.38 / 3/32"	24-50400	24-55100	24-51400	3.2	4.5	6.2	2.7	2.1	0.76	60	3.8	9.2	20.6	14.2
3.18 / 1/8"	24-50100	24-55200	24-51100	4.4	6.0	8.2	3.6	2.4	1.14	100	3.8	9.2	20.6	14.2
3.97 / 5/32"	24-50500	24-55300	24-51500	5.5	7.5	10.2	4.4	2.8	1.55	100	3.8	14.2	35.0	20.6
4.77 / 3/16"	24-50600	24-55300	24-51600	6.6	9.0	12.3	5.2	3.2	1.55	100	3.8	14.2	35.0	20.6
6.35 / 1/4"	24-50200	24-55400	24-51200	8.8	12.0	16.4	6.9	3.9	2.39	150	3.8	14.2	35.0	20.6
9.58 / 3/8"	24-50300	24-55500	24-51300	13.2	18.0	24.5	10.3	5.5	2.39	150	3.8	18.3	44.5	25.4

oboustranný odhrotovač

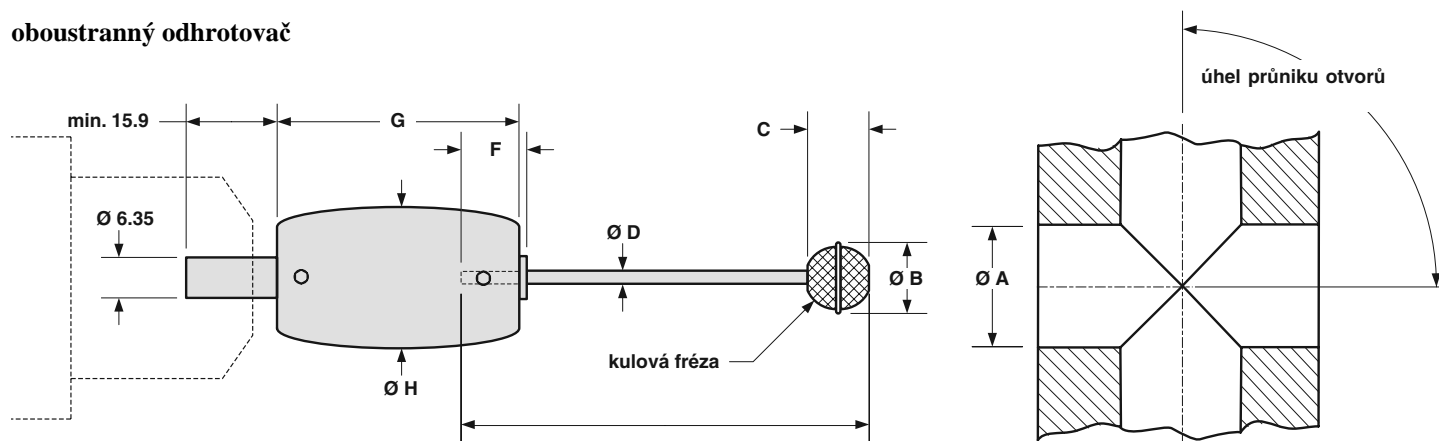

doporučení:
stopku je potřeba zkrátit na optimální délku

rozměr mm/"	obj. číslo			min. průměr otvoru A v závislosti na úhlu průniku otvorů			Ø B nákržek	C výška frézy	Ø D stopka	E délka stopky	F		G	Ø
	H kompletní nástroj	pružný držák	fréza	90°	60°	45°					min.	max.		
2.38 / 3/32"	24-52400	24-55100	24-53400	3.2	4.5	6.2	2.7	3.2	0.76	60	3.8	9.2	20.6	14.2
3.18 / 1/8"	24-52100	24-55200	24-53100	4.4	6.0	8.2	3.6	3.9	1.14	100	3.8	9.2	20.6	14.2
3.97 / 5/32"	24-52500	24-55300	24-53500	5.5	7.5	10.2	4.4	4.6	1.55	100	3.8	14.2	35.0	20.6
4.77 / 3/16"	24-52600	24-55300	24-53600	6.6	9.0	12.3	5.2	5.4	1.55	100	3.8	14.2	35.0	20.6
6.35 / 1/4"	24-52200	24-55400	24-53200	8.8	12.0	16.4	6.9	6.8	2.39	150	3.8	14.2	35.0	20.6
9.58 / 3/8"	24-52300	24-55500	24-53300	13.2	18.0	24.5	10.3	10.1	2.39	150	3.8	18.3	44.5	25.4